

ELECTRIC MULTI DIRECTIONAL SIDELOADER

BASIX -
QUIET, SAFE
AND SUITABLE
FOR INDOOR
AND OUTDOOR
APPLICATIONS



LOAD CAPACITIES OF UP TO 3.0 TONNES
MAST HEIGHTS UP TO 7500 MM

www.hubtex.com

HUBTEX.

WE CREATE THE UNIQUE

BASIX

ECONOMICAL AND UNIVERSAL

The HUBTEX models DS 27 and DQ 30 E form the entry-level variant of electric multidirectional sideloaders with elastic tyres for combined indoor and outdoor use.

The BasiX range provide truly universal sideloaders with multidirectional steering, designed for the handling of pallets, long loads and medium to heavy loads in narrow aisle applications.

The units are used by DIY stores, Building Merchants, Window Profile Manufacturers and many, many more.

Electric multidirectional sideloaders

The HUBTEX multidirectional forklifts are electrically driven. The high-performance steering system was specially developed for the new series and sets new standards for three-wheel four-way forklifts in terms of manoeuvrability and safety. Optimised pumps reduce noise levels to a minimum.

- *Load capacities up to 3.0 tonnes*
- *Proportional valve technology
stepless operation and jerk-free for all lift mast functions*
- *Multi-directional steering
with longitudinal, transverse and circular travel*
- *Easy battery replacement*
- *Low entry height for the DS 27,
large steps for the DQ 30 E*

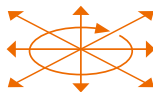

Features	DS 27 (3117)	DQ 30 E (3120)
Load capacity (t)	up to 2.7	up to 3.0
Useful width (mm)	800 / 1000 / 1200	1000 / 1200
Lift height (mm)	up to 7500	up to 7500
Frame length (mm)	2500	2250
Wheel arm opening (mm)	1450	1230
Tyres (optional) ¹	EL	EL
Battery voltage (V)	48	48
Cab ²	SU	Q

1) EL = Elastic 2) Q = Transverse, SU = Stand Up

- *Minimal noise emission
through the use of special "Silent Pumps"*
- *Large dimensioned elastic tyres
also suitable for uneven ground*
- *High performance steering system
for the fastest wheel changeover times*

Increased storage capacities – optimal utilisation



UP TO 100% MORE STORAGE SPACE

FAST, SAFE AND EFFICIENT

REDUCED DAMAGE TO THE GOODS

HANDLING OF LONG GOODS AND PALLETS

HUBTEX sideloaders operate in narrow aisles and can be driven without any problems and the distance between the rack rows can be reduced to a minimum. This creates additional space allowing increases in storage capacity.

HUBTEX VEHICLES SOLVE ALL HANDLING TASKS

Long or heavy loads with load capacities from 1.5 to 3.0 tonnes for large-volume loads

- Electric drive
- Indoor and outdoor use
- Handling / Transport / Order picking
- Forced guidance in narrow aisle or freely movable

HUBTEX.

For long, heavy and bulky loads

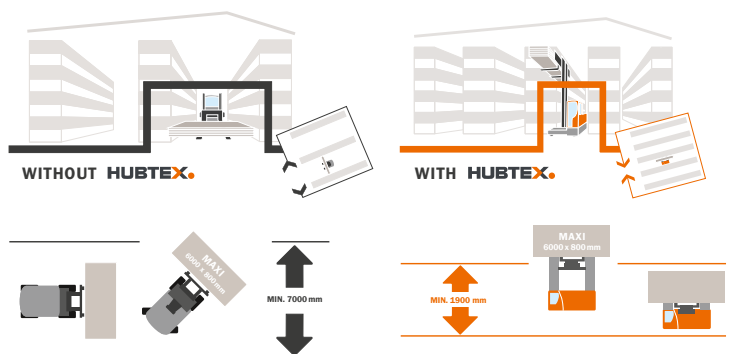

Sturdy and robust mast systems

➤ FORK CARRIER AND BOOM

HUBTEX inhouse manufacture of masts provides sturdy and robust mast systems with internal, protected hydraulics provide large reserves of lifting capacity. HUBTEX offers different lift mast variants and fork carriers for safe and efficient handling.

Hydraulic fork adjustment is available as an option.

Standard fork carrier Type I

This fork carriage is suitable for handling plates, rigid long goods or cassettes with fork pockets. It offers the driver an excellent view of the load.

Long goods fork carrier Type II

Flexible solution for handling pallets and long goods of all kinds. The HUBTEX fork carrier Type II has an extremely low overall height for the best possible utilisation of the available room height.

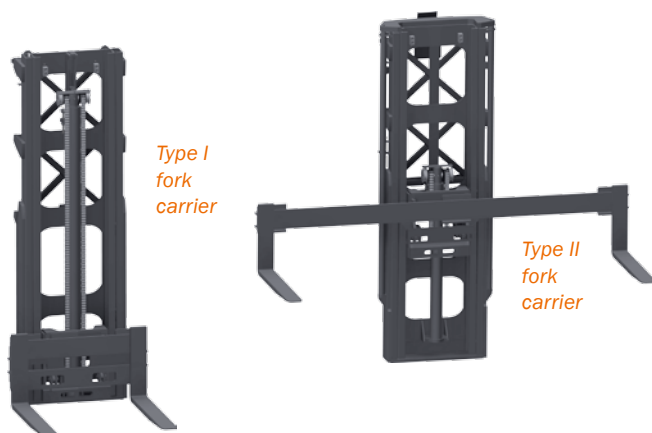

The fork carriers can be combined with all booms



➤ CAB

The ergonomically designed workplace offers plenty of freedom of movement and excellent visibility to all sides. All operating elements are clearly arranged and easily accessible.

Driver's cab on the DS 27

The fully adjustable backrest ensures fatigue-free working. Instead of a dead man's button, a contact plate is installed in the cab floor to increase the driver's freedom of movement. The low entry height ensures fast entry and exit.

Cross seat cab

This Q-cab is the first vehicle in its class to dispense with the mast side cab column. The newly designed cover of the working hydraulics reduces "blind spots" especially in the main direction of travel. Operation is via the familiar HUBTEX joystick and steering wheel.

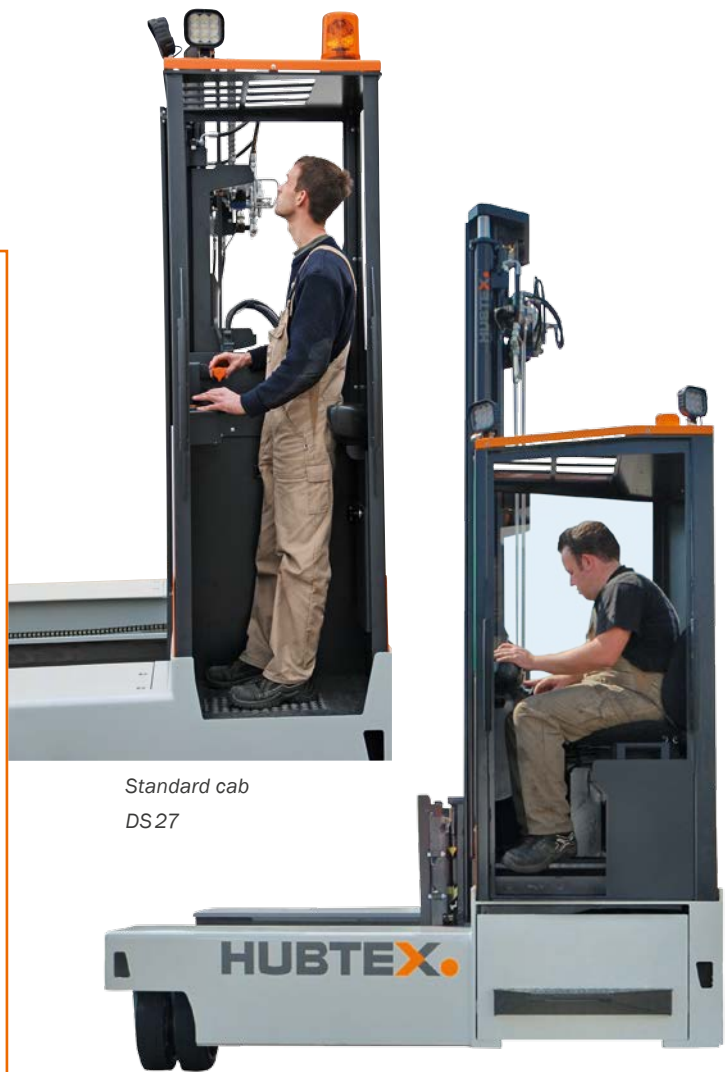

Standard cab
DS27

Cross seat cab
DQ30E



➤ BATTERY REPLACEMENT

The HUBTEX DQ 30E features a very simple battery change. The battery, consisting of two standard DIN troughs, is built into the base frame and can be easily removed with a manual pallet truck.



In addition, the low installation height improves the centre of gravity of the device, thereby improving stability.

➤ TYRES

As a universal device for indoor and outdoor use, HUBTEX uses large dimensioned elastic tyres, which also drive excellently on asphalt and paved surfaces.

Compact double wheels are used on the load side to reduce wheel wear.

➤ MULTI-DIRECTIONAL STEERING

As one of the first electric three-wheel four-way forklifts, the HUBTEX vehicles are equipped with multi-directional steering. In addition to transverse, longitudinal and circular travel, this vehicle also offers diagonal travel as standard. The high-performance steering is also characterised by fast changeover times.

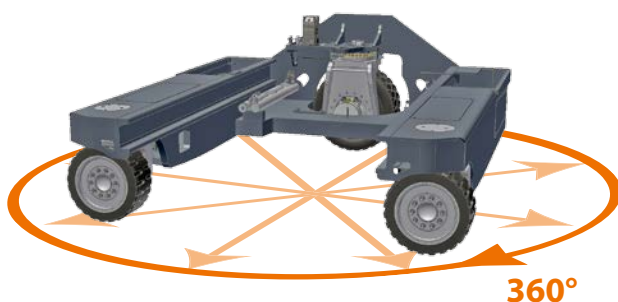

HUBTEX VEHICLES

ELECTRIC-MULTIDIRECTIONAL-SIDELOADERS › DIESEL-/GAS-FOUR-WAY-SIDELOADERS › MULTIDIRECTIONAL COUNTERBALANCE FORKLIFT › ORDER PICKING SYSTEMS › GLASSTRANSPORT SYSTEMS › HEAVY DUTY TRANSPORT VEHICLES › REACH TRUCKS › SPECIAL TRUCKS › SECOND-HAND-AND RENTAL EQUIPMENT

HUBTEX.

WE CREATE THE UNIQUE

HUBTEX MASCHINENBAU GMBH & CO. KG · Industriepark West · Werner-von-Siemens-Str. 8 · 36041 Fulda, Germany
Tel.: +49 661 8382-0 · Fax: +49 661 8382-120 · info@hubtex.com · www.hubtex.com