

ELECTRIC MULTI DIRECTIONAL SIDELOADER

PHOENIX -
EQUIPPED FOR
THE FUTURE



LOAD CAPACITIES UP TO 7 TONS
LIFT HEIGHTS UP TO 14000 MM

www.hubtex.com

HUBTEX.

WE CREATE THE UNIQUE

PHOENIX

FUTURE- PROOF INNOVATION

Our sideloaders with multidirectional steering from the Phoenix truck series can be flexibly adapted to the individual requirements of the customer.

Customers can choose from a variety of series with application-specific fork carriage designs, cabins, lift masts and individual equipment options to find their ideal solution. As these series offer an almost endless number of possible combinations, a HUBTEX multidirectional sideloader can be perfectly adapted to any application.

Electric multidirectional sideloader **PHOENIX** in detail

Operator comfort

- Perfect all-round visibility
- Mast with a clear view in the direction of travel A
- Ergonomic cabin design
- Easy access
- Simplified battery replacement

Technical benefits

- Increased battery capacity (48 V)
- Low energy consumption
- Patented HX steering



INNOVATIONS

- Electric steering
- AGV-ready
- Vehicle positioning and navigation
- Weight and overload display depending on lift height

Series	2820	2821	2829	2830	2831
Load capacity (t) ¹	1.5 – 3.0	1.5 – 3.0	3.0 – 4.5	3.0 – 5.0	5.0 – 7.0
Lift height h3 (mm)	up to 8500	up to 8500	up to 12000	up to 12000	up to 14000
Frame cutout Ra (mm)	1000	1340	1340/1630/1960	1340/1630/1960	1340/1630/1960
Frame length (mm)	2100	2760	2880/3170/3500	2880/3170/3500	2880/3170/3500
Driving speed (km/h) ²	8	8	9	9	9
Tyres	EL or PU	EL or PU	EL or PU	EL or PU	PU
Battery (V)	48	48	48	80	80

¹ Load centre 600 mm ² Longitudinal travel

Increased storage capacities ensure optimal utilisation



UP TO 100% MORE STORAGE SPACE

FAST, SAFE AND EFFICIENT

LESS DAMAGE TO THE GOODS

With the HUBTEX sideloader, narrow aisles can be navigated without any problems. The distances between the rows of shelves can be reduced to a minimum, creating extra space for additional storage. HUBTEX thus ensures increased storage capacity and as a result offers optimal use of storage space.

SMALLER AISLE WIDTHS THANKS TO MULTIDIRECTIONAL STACKERS

Vehicles can be used for long or heavy loads and offer load capacities from 1.5 to 7.0 tons for large-volume loads

- *Electric drive*
- *For indoor and outdoor applications*
- *Handling / transport / order picking*
- *Positively driven in a narrow aisle or freely mobile*

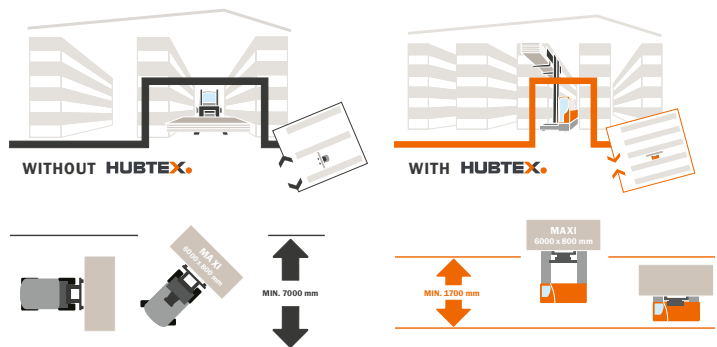

HUBTEX.



MQ45 PHOENIX

With the new Phoenix series, every consultation aims to individually configure the truck specification to the application requirements.

Comfortable and optimally equipped with **PHOENIX**

All HUBTEX vehicles are specially manufactured industrial trucks that can be tailored to your specific business application. In order to satisfy all of your requirements, HUBTEX offers a variety of different equipment options.



The driver and customer service information can also be read remotely.

➤ DRIVER'S CABIN

The spacious cabin offers the driver the greatest possible comfort and freedom of movement.

All of the truck information is clearly shown on the HIT3 colour display (HUBTEX information terminal). In most cabin variants, the HIT3 is mounted on an adjustable holding arm so that the operator can individually select the optimum terminal position.

All hydraulic functions and the direction selection function are controlled as standard via the ergonomic multifunction joystick. The height and angle of the steering column can be adjusted to offer the driver additional comfort.

Ergonomics

The spacious and ergonomically designed workspace offers greater freedom of movement and an unrestricted view on all sides. The vibration-damped cabin and the sprung, multi-adjustable comfort seat ensure fatigue-free, smooth operation and protect the health of the driver.

Optimum all-round visibility

Thanks to the new generation of cabins, which have already proven successful in other series, and the modernisation of the existing mast types, the trucks offer the best visibility in their class.

Joystick with integrated direction switch

All hydraulic functions, as well as the preselection of the driving direction, can be controlled smoothly and with millimetre precision using a joystick developed by HUBTEX. The crucial movements such as lifting, lowering, mast advancement/retraction, fork tilt and fork adjustment can be actuated quickly and safely without having to change your grip.



Cabin variants for the smallest working aisle widths and the greatest possible comfort

- Cross-seat cabin (Q)
- Diagonal-seat cabin with fixed seat (DF 770)
- Diagonal-seat cabin with swivel seat (DS 770)
- XL diagonal-seat cabin (DXL)
- Lateral-seat cabin (L)
- Stand-up cabin (SU)

Cabin accessories

- Working headlamp which can be manually adjusted from the cabin
- Manually adjustable LED working headlamp on the cabin top
- Flashing beacon
- Interior cabin lighting
- Radio/CD including two speakers
- Fully glazed cabin
- Lockable door with sash window (Q cabin)
- Electric heating
- Windshield wiper
- Heated driver's seat (Q cabin)



➤ PENDULUM FRAME

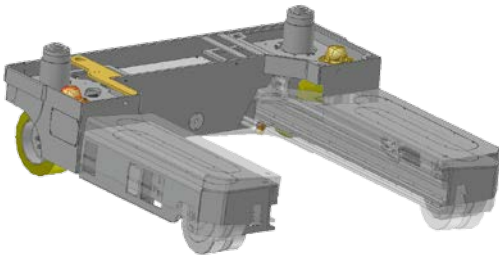

The two-part chassis frame, which has been tried and tested over decades, ensures that all wheels are in constant contact with the ground. The truck immediately compensates for any unevenness on the ground. This protects the components as well as the health of the operator. It also prevents cracks in the chassis frame.

➤ MULTIDIRECTIONAL STEERING SYSTEM

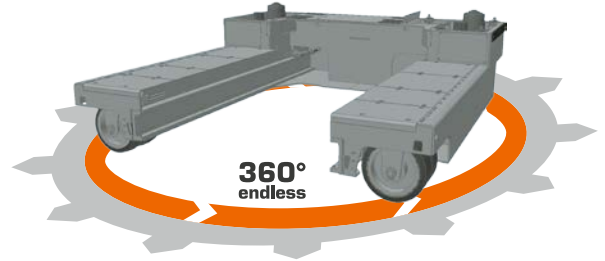

In **longitudinal travel**, the HUBTEX can quickly transport long material through narrow gates and aisles. The lift truck can also be used as a conventional frontloader in **transverse travel**. **Circular driving** under static conditions makes it possible to turn quickly. **Diagonal drive** mode enables safe handling when loading and unloading trucks.

THE ALL-NEW ELECTRIC MULTIDIRECTIONAL SIDELOADERS

➤ UP TO 85% LESS ENERGY CONSUMPTION THANKS TO ELECTRIC STEERING

Purely electric steering is now available as an option with the first electric multidirectional sideloader in the Phoenix series. This reduces the steering noise to a minimum. In addition, the use of electric steering leads to significantly lower energy consumption. The tried-and-tested electro-hydraulic steering is still available as standard.

➤ OPTIONAL HX MULTIDIRECTIONAL STEERING SYSTEM

The mobility of the truck offers a great advantage and can save space in the warehouse by up to 50%. Equipped with the patented HX steering system, which is available exclusively from HUBTEX, the Phoenix can switch from longitudinal to transverse travel without stopping. This reduces the time required to adjust the wheels and offers optimal manoeuvrability.

> LIFT MASTS AND FORK CARRIER

Stable and robust lift masts produced in-house with internal, protected hydraulics and large load capacity reserves. HUBTEX manufactures different lift masts and fork carriers for safe and efficient handling for loads of all types. Hydraulic fork adjustment and a side shifter are also available as options.

Telescopic fork carrier

For extremely unstable long goods or loads of varying lengths, HUBTEX manufactures telescopic fork carriers with the option of 2 or 4 fork arms. The version and adjustment range can be tailored to the loads (not shown).

Top fork carrier with two additional fork arms

The top fork carrier with quick-change system is available as an option for manual pick-up with the type I standard fork carrier. This option is intended for short-term handling of long goods (not shown).

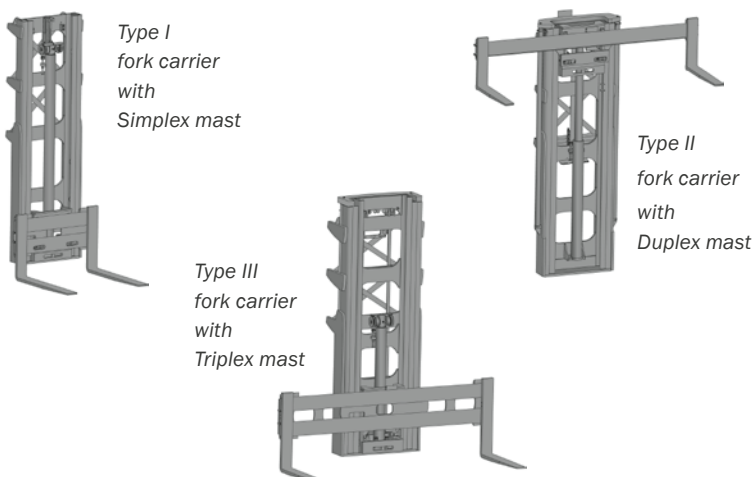

The fork carriers can be combined with all lift masts



> TYRES



Polyurethane
(PU)

Elastic (EL)

Elastic with
tread pattern (EL)

HUBTEX offers a choice of tyres for different requirements. These include polyurethane tires (PU) for smooth industrial floors and soft elastic tires (EL) for poor-quality floors or outdoor use to protect the components and the health of the driver.

> LIGHTING



“See and be seen” is the overall aim of this component. HUBTEX offers various lighting options in the chassis frame to ensure optimal safety on your company premises.



➤ FORK ARMS

HUBTEX offers the right fork arms to suit every application. As an essential part of the device, the fork arms are subject to specific requirements. The use of high quality products ensures minimal wear with high load capacities.

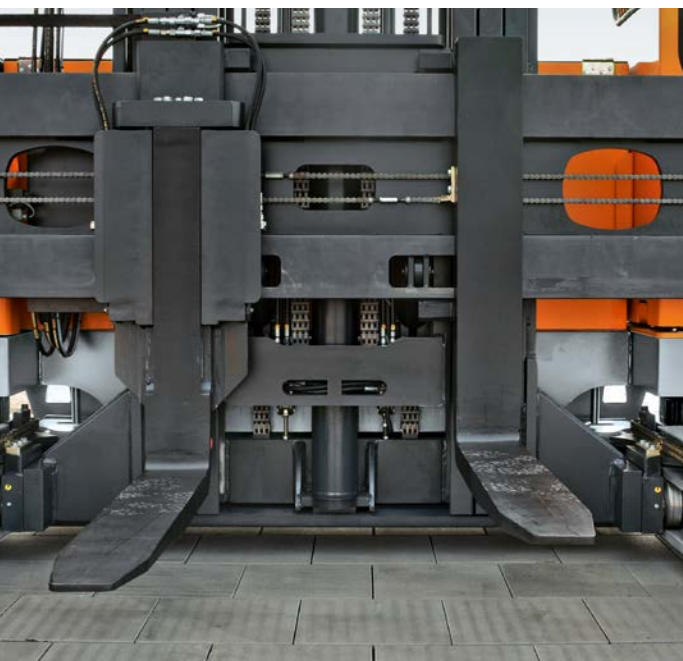

Height-adjustable fork arm (level compensation)

In order to compensate for unevenness, lift fork arms are available for all load capacities and can be used in combination with telescopic forks.

Blade forks

Blade forks are available at an added cost for load pick-up in extremely narrow gaps (not shown).



Basic position



Extended telescopic forks

Telescopic forks

For single-sided loading and unloading of trucks or double-deep storage on shelves, telescopic forks (manual or hydraulic) in all lengths and load capacities are available as an option for HUBTEX lift trucks.

➤ STORAGE AIDS

Additional storage aids are available from HUBTEX for safe and efficient handling at high lifting heights or in tightly compact shelves.

Video camera with flat screen

Cameras perform valuable functions in many industries. They increase safety, improve visibility during storage and optimise the load on the lift truck. The range includes robust and compact cameras and displays with a large number of special cables and plug connections to ensure smooth and continuous image transmission. The cameras are either assembled on the fork arm, on the fork carrier or on the lift mast.



HUBTEX Load Manager (HLM)

The HLM is an electronic device with 99 freely-programmable lift height positions. The lift mast stops at the pre-selected rack level. The system differentiates whether goods are moved in or out of storage. By preventing uncontrolled penetration into the rack compartment, the HLM saves time and reduces damage to the goods.

Additional accessories

- *Intermediate stroke limiting*
- *Mast extension limitation*
- *Secutex coating*
- *Lift height indicator*
- *Load Moment Monitor*
- *Acoustic warning signal*
- *Distance warning sensors*
- *Radio/CD player*
- *and many other safety innovations*

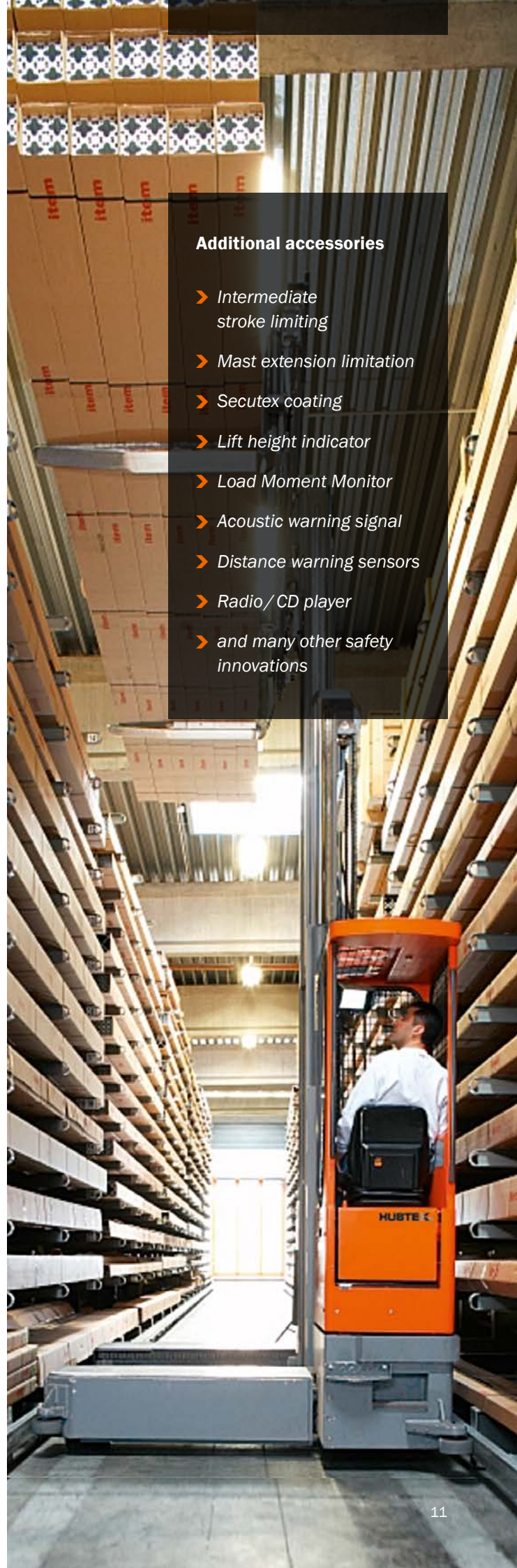

➤ TRACK GUIDING SYSTEMS

HUBTEX offers three different track guiding systems for narrow aisle solutions to maximise the use of the available storage space. With a safety distance of just 100 mm per side, the aisle width is reduced to a minimum.



Rack guiding rollers

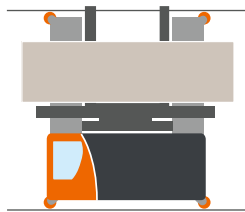

Rack guiding rollers (100 mm safety distance per side) are available as a single version up to 4.5 t and as a dual version from 4.5 t. This mechanical guidance system is robust and proven in operation.

Inductive track guidance

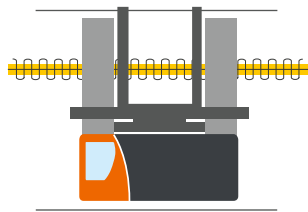

Inductive track guidance (150 mm safety distance on each side) is a reliable and safe system with the added advantage that your HUBTEX vehicle is already following the guide wire before accessing the rack, thereby eliminating damage to the device or the rack itself.

Optical track guidance system

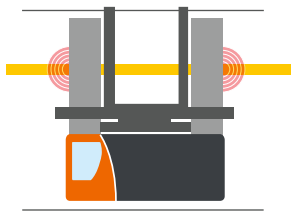

The optical track guidance system (150 mm safety distance per side) is based on inductive guidance technology but is used when there is no iron-free area on the ground in order to lay the guide wire.



Inductive track guidance

An iron-free area is required around the guide wire in accordance with DIN 15185 Part 1. When investing in a new device with an aisle length of ≥ 400 linear metres, this is the most cost-effective guidance system.

➤ PERSONAL SECURITY SYSTEMS IN THE POSITIVELY-DRIVEN NARROW AISLE WAREHOUSE

In the case of working aisle widths with safety distances of less than 500 mm per side, the operator of the system is obliged to install accredited personal security systems in accordance with DIN 15185 Part 2 "Personal protection when using industrial trucks in narrow aisles". HUBTEX offers two different personal security systems. Both systems comply with the applicable directive.

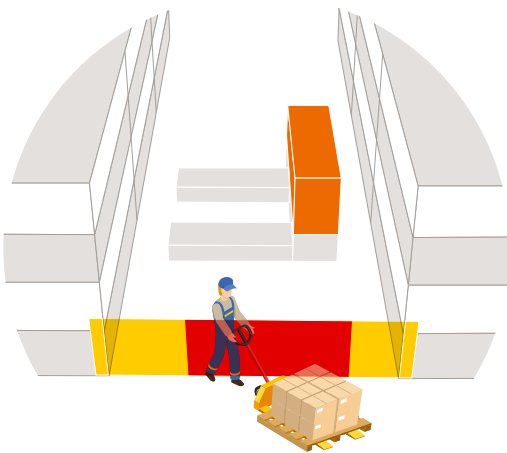

Stationary aisle protection

- *Alternative to mobile PPE*
- *Automatic protective device*
- *Protection of people when using industrial trucks in narrow aisles*
- *Approved by the authorities*
- *Cost-effective alternative for up to three storage aisles*
- *Optional: escape door monitoring/ escape route monitoring*

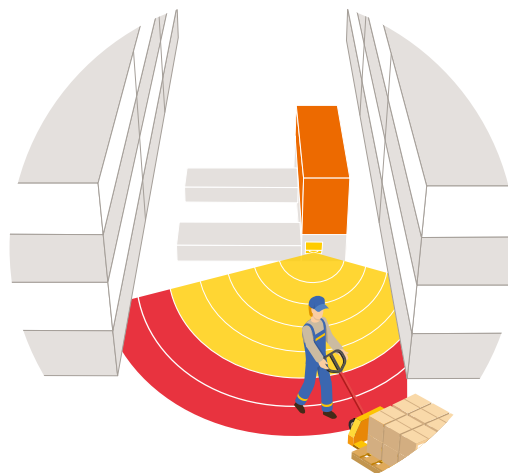

HUBTEX mobile personal protection equipment (PPE)

- *Storage aisle monitoring via two laser scanners*
- *If people or obstacles are detected in the aisle, your HUBTEX brakes automatically to a standstill*
- *Can be used regardless of the number of storage aisles*
- *Two aisle detection systems*

PSA-mobil personal protection equipment





New and innovative: laser navigation for narrow aisles

➤ GUIDANCE VIA LASER NAVIGATION

Object-based laser navigation uses the raw data from personal protection scanners or 2D laser scanners. The HUBTEX vehicle control system creates maps of the surrounding area based on the data obtained. The vehicle then identifies its own position on the map and is able to follow defined routes with an accuracy of up to ± 15 mm. The process takes into account changes in the environment.

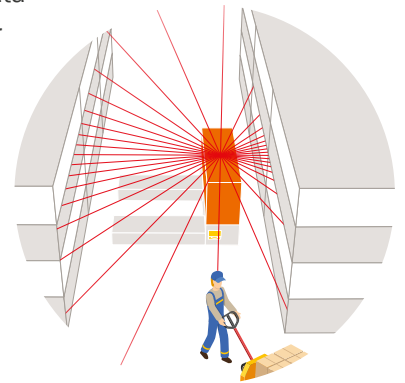

➤ AUTOMATIC VEHICLE POSITIONING

Horizontal and vertical vehicle positioning is available as an add-on for laser localisation. The positioning of the rack compartment is determined by a horizontal and vertical positioning device and a touch panel in the cabin. Rack positioning is activated once the rack position is entered manually into the HUBTEX touch panel. By pressing lift on the joystick and pressing the accelerator pedal, the shelf is approached semi-automatically.

➤ WMS CONNECTION

The next stage to achieving automatic vehicle positioning is to connect the multidirectional truck to the Warehouse Management System (WMS). The target height for storage/retrieval is transmitted directly from the WMS to the automatic vehicle positioning system. The driver simply has to activate the lift function. When lifting, the fork automatically stops at the correct height.

Step-by-step automation

There are many possible uses for electric multidirectional sideloaders. HUBTEX already offers a large number of interrelated systems.

For example, there is often a natural progression from assisted operation, e.g. with intelligent route guidance, to track-guided operation and later automated operation. In the future, even complex transport tasks will be carried out automatically and multidirectional side-loaders can be fully integrated into automated production processes.

The trucks can be used flexibly and carry out their transport tasks quickly, efficiently and reliably. Customers with high turnover rates benefit from this in particular.

The result is reduced throughput costs combined with a reduction in operating costs, as well as optimised material flows and an increase in efficiency.

HUBTEX remote maintenance

A new remote maintenance system is available for HUBTEX vehicles. Important truck data, such as error codes and battery charge status, is transferred to the cloud environment of the system partner Telekom via an M2M gateway on the lift trucks.

In the event of a truck malfunction, HUBTEX technicians can directly access the vehicle data and provide rapid assistance.

Customers benefit from maximum machine availability and minimised production downtimes. The system can also be retrofitted to used vehicles.



➤ THE REMOTE MAINTENANCE SYSTEM AT A GLANCE:

- Automated exchange of information between truck and Service department
- Data transfer of error codes, battery charge status and operating hours
- Functions for parameter change and software updates are available
- Maximum machine availability, minimised production downtimes and service work

HUBTEX VEHICLES

ELECTRIC-MULTIDIRECTIONAL-SIDELOADERS › DIESEL-/GAS-FOUR-WAY-SIDELOADERS › MULTIDIRECTIONAL COUNTERBALANCE FORKLIFT › ORDER PICKING SYSTEMS › GLASSTRANSPORT SYSTEMS › HEAVY DUTY TRANSPORT VEHICLES › REACH TRUCKS › SPECIAL TRUCKS › SECOND-HAND-AND RENTAL EQUIPMENT

HUBTEX.

WE CREATE THE UNIQUE

HUBTEX MASCHINENBAU GMBH & CO. KG · Industriepark West · Werner-von-Siemens-Str. 8 · 36041 Fulda, Germany
Tel.: +49 661 8382-0 · Fax: +49 661 8382-120 · info@hubtex.com · www.hubtex.com