

Series 2121 - PUS OP, Model M 15 / 20

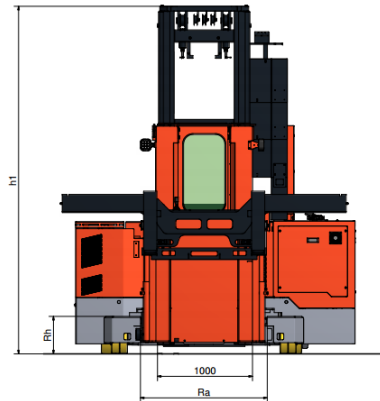

- Multidirectional steering
- Electric drive
- Capacities up to 2000 kg
- Lift heights up to 7500 mm
- Loadbed width up to 1600 mm



Kabinentypen / cabin types

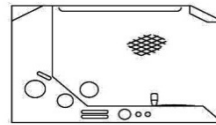

Standkabine / stand up cabin

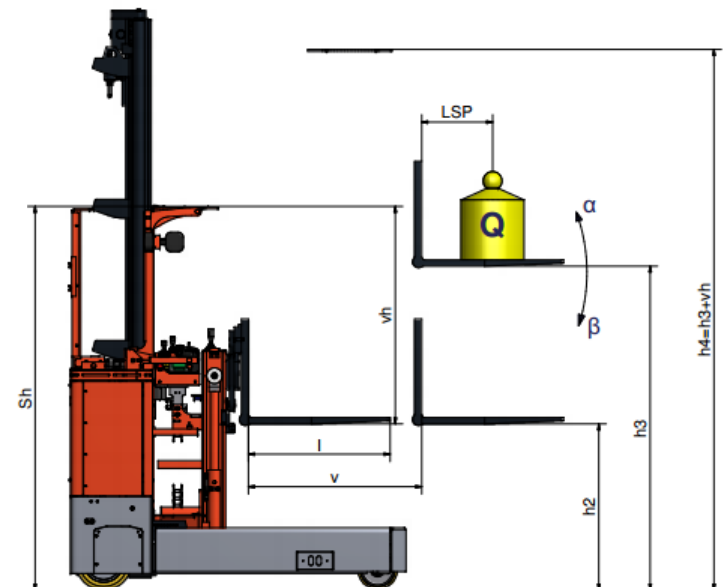
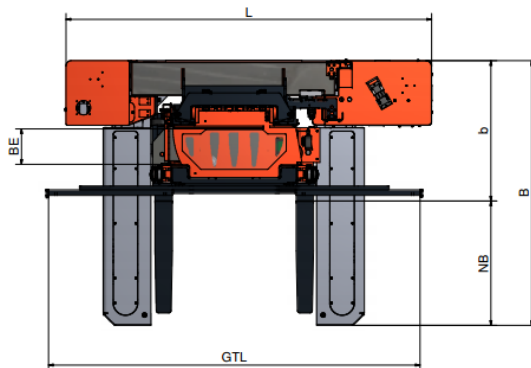
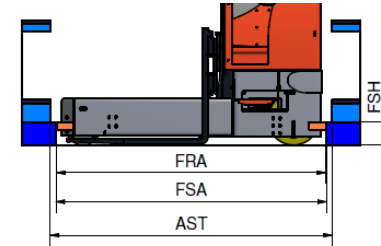

ELECTRIC MULTIDIRECTIONAL SIDELOADER

Characteristics	1.1	Serie		2121-PUS1 OP		2121-PUS OP		
	1.2	Model	Manufacturer's identification	M 15	M 20	M 15	M 20	
	1.3	Capacity	Q at standard lift height	kg	1500	2000	1500	2000
	1.4	Loadcenter	lc = distance	mm	500	500	500	500
	1.6	Power supply	electric / Diesel / LPG		electric	electric	electric	electric
	1.7	Type of steering	V = fourway / M = multidirectional / 2 = towway		M	M	M	M
	1.71	Position of seat	Q = cross / D = diagonal / L = lateral / SU = stand up		SU	SU	SU	SU
	1.8	Tyres	PU = Vulkollan / EL = elastic		PU	PU	PU	PU
	1.9	Wheels (X = powered)	number	pcs.	6 / 1X	6 / 1X	6 / 2X	6 / 2X
Dimensions	2.1	Mast	h3 = lift height standard / max.	mm	3000 - 7500	3000 - 7500	3000 - 7500	3000 - 7500
	2.21	Fork cross section	s / b = thickness / width	mm	40 / 120	40 / 120	40 / 120	40 / 120
	2.22	Fork length	l = NB from / to	mm	800 - 1400	800 - 1400	800 - 1600	800 - 1600
	2.23	Fork tilt	standard	degree	+5 / -3	+5 / -3	+5 / -3	+5 / -3
	2.31	Overall dimensions	L = truck length	mm	2950	2950	2950	2950
	2.32		Sh = height over cabin roof "Q"	mm	2420	2420	2420	2420
	2.33		b = width to edge of forks	mm	1030 / 1100	1030 / 1100	1030 / 1100	1030 / 1100
	2.34		NB = loadbed width from / to	mm	750 - 1200	750 - 1200	750 - 1200	750 - 1200
	2.35		B = truck width (at NB 1200 mm)	mm	2030 / 2100	2030 / 2100	2030 / 2100	2030 / 2100
	2.36		Rh = loadbed height	mm	390	390	390	390
	2.37		Ra = loadbed opening	mm	1340	1340	1340	1340
	2.4	Mast reach	V (at NB 1200 mm)	mm	1100	1100	1100	1100
	2.52	Aisle width	AST (at NB 1200 mm)	mm	2230 - 3100	2230 - 3100	2230 - 3100	2230 - 3100
Wght.	3.1	Empty weight	incl. battery	appr. kg	5000	5000	5100	5100
	3.2	Floor load	incl. nominal load (static)	N/cm ²	480	480	510	510
Performance	4.1	Stability	according to CE-regulations	yes/no	yes	yes	yes	yes
	4.21	Speeds	travel speed with / without nominal load	km/h	6 / 6	6 / 6	8 / 8	8 / 8
	4.22		lifting speed with / without nominal load	m/s	0,20 / 0,25	0,20 / 0,25	0,20 / 0,25	0,20 / 0,25
	4.23		lowering speed with / without nominal load	m/s	0,30 / 0,25	0,30 / 0,25	0,30 / 0,25	0,30 / 0,25
	4.24		mast travel speed with / without nominal load	m/s	0,20 / 0,20	0,20 / 0,20	0,20 / 0,20	0,20 / 0,20
4.31	Ramp capability	max. with / without nominal load	%	0 / 0	0 / 0	0 / 0	0 / 0	
Wheels + tyres	5.11	Tyres	number load side / drive side	pcs.	4 / 2	4 / 2	4 / 2	4 / 2
	5.12		Abmessungen Lasträder	mm	250 x 80			
	5.13		Abmessungen Antriebsräder	mm	343 x 114			
	5.3	Bodenfreiheit		mm	75	75	75	75
	5.41	Betriebsbremsen			via drive pedal activated electrical plugging brake			
5.42	Feststellbremse			spring-loaded brake with electromagnetic release				
Drive unit	6.11	Batterie	Spannung / Kapazität	V/Ah	48 V - 3 EPzS - 465 Ah / 48 V - 4 EPzS - 620 Ah			
	6.12		Minimalgewicht	Kg	800 / 950	800 / 950	800 / 950	800 / 950
	6.21	Elektromotoren	Fahrmotor (s2=60 min)	KW	1 x 4,0	1 x 4,0	2 x 4,0	2 x 4,0
	6.22		Hubleistung	KW	1 x 8,0	1 x 8,0	1 x 8,0	1 x 8,0
	6.23		Lenkleistung	KW	1 x 3,0	1 x 3,0	1 x 3,0	1 x 3,0
	6.31	Schaltung	Art		AC-controls	AC-controls	AC-controls	AC-controls
	6.4	Getriebe	Art		straight bevel	straight bevel	straight bevel	straight bevel
6.5	Arbeitsdruck	für Anbaugeräte	bar	180	180	180	180	