

# Series 2140 - PUS OP, Model M 15 / 20

# HUBTEX.

- Multidirectional steering
- Electric drive
- Capacities up to 2000 kg
- Lift heights up to 8000 mm
- Loadbed width up to 1200 mm

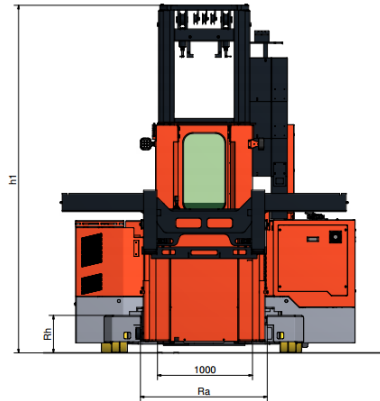

## Kabinentypen / cabin types

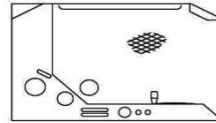

Standkabine / stand up cabin

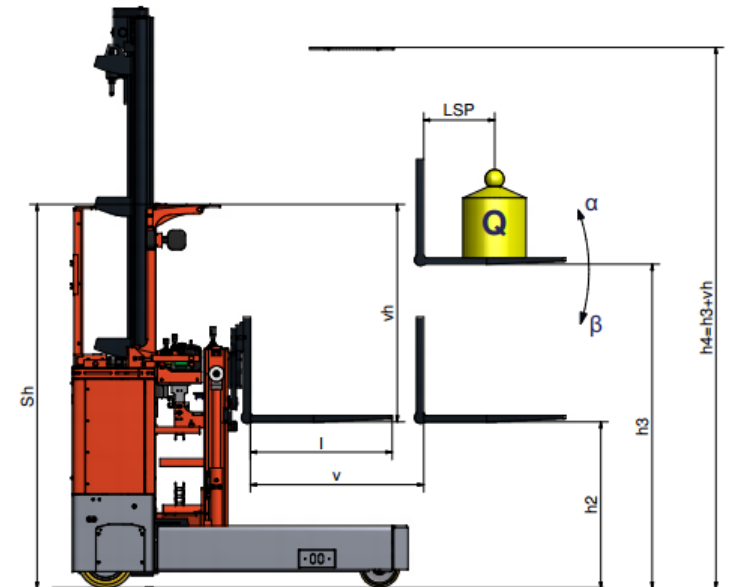
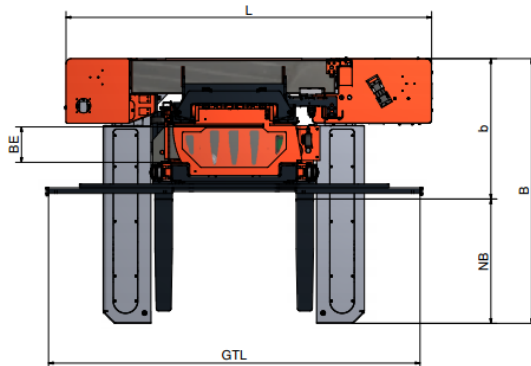
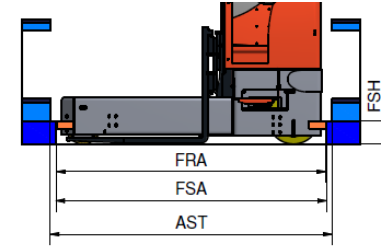

## ELECTRIC MULTIDIRECTIONAL SIDELOADER

Characteristics	1.1	Series		2140-PUS OP		
	1.2	Model	Manufacturer's identification	M 15	M 20	
	1.3	Capacity	Q at standard lift height	kg	1500	2000
	1.4	Loadcenter	lc = distance	mm	500	500
	1.6	Power supply	electric / Diesel / LPG		electric	electric
	1.7	Type of steering	V = fourway / M = multidirectional / 2 = tow way		M	M
	1.71	Position of seat	Q = cross / D = diagonal / L = lateral / SU = stand up		SU	SU
	1.8	Tyres	PU = Vulkollan / EL = elastic		PU	PU
	1.9	Wheels (X = powered)	number	pcs.	6 / 2X	6 / 2X
Dimensions	2.1	Mast	h3 = lift height standard / max.	mm	3000 - 8000	3000 - 8000
	2.21	Fork cross section	s / b = thickness / width	mm	40 / 120	40 / 120
	2.22	Fork length	l = NB from / to	mm	600 - 1200	600 - 1200
	2.23	Fork tilt	standard	degree	+5 / -3	+5 / -3
	2.31	Overall dimensions	L = truck length	mm	3640	3640
	2.32		Sh = height over cabin roof "SU"	mm	2580	2580
	2.33		b = width to edge of fork (BE = 340 mm)	mm	1200	1200
	2.34		NB = loadbed width from / to	mm	600 - 1200	600 - 1200
	2.35		B = truck width (at NB 1000 mm)	mm	2.200	2.200
	2.36		Rh = loadbed height	mm	415	415
	2.37		Ra = loadbed opening	mm	1630	1630
	2.4	Mast reach	V (at NB 1000 mm)	mm	1100	1100
	2.52	Aisle width	AST (at NB 1000 mm)	mm	2400 - 3200	2400 - 3200
Wght.	3.1	Empty weight	incl. battery	appr. kg	8300	8500
	3.2	Floor load	incl. nominal load (static)	N/cm²	540	560
Performance	4.1	Stability	according to CE-regulations	yes/no	yes	yes
	4.21	Speeds	travel speed with / without nominal load	km/h	6 / 6	6 / 6
	4.22		lifting speed with / without nominal load	m/s	0,20 / 0,25	0,20 / 0,25
	4.23		lowering speed with / without nominal load	m/s	0,30 / 0,25	0,30 / 0,25
	4.24		mast travel speed with / without nominal load	m/s	0,20 / 0,20	0,20 / 0,20
	4.31	Ramp capability	max. with / without nominal load	%	0 / 0	0 / 0
Wheels + tyres	5.11	Tyres	number load side / drive side	pcs.	4 / 2	4 / 2
	5.12		dimensions load wheels	mm	300 x 100	
	5.13		dimensions drive wheels	mm	406 x 200	
	5.3	Ground clearance		mm	75	75
	5.41	Service brakes			via pedal activ. electr. plug. br.	
	5.42	Parking brake			spring-l. br. with electrom. rel.	
Drive unit	6.11	Battery	capacity	V/Ah	80 V - 4 EPzS - 620 Ah	
	6.12		minimum weight	kg	1600	1600
	6.21	Electric motors	drive motor rating (s2 = 60 min)	kW	2 x 3,5	2 x 3,5
	6.22		lifting motor rating	kW	1 x 19,3	1 x 19,3
	6.23		steering motor rating	kW	1 x 4,0	1 x 4,0
	6.31	Electric controls	type		AC-controls	AC-controls
	6.4	Transmission	gear type		planetary	planetary
	6.5	Hydraulic pressure	for attachments	bar	180	180