

# Series 2410 - EL, Model FluX 30

# HUBTEX.

- > HX steering
- > Electric drive
- > Capacities up to 3000 kg
- > Lift heights up to 7500 mm

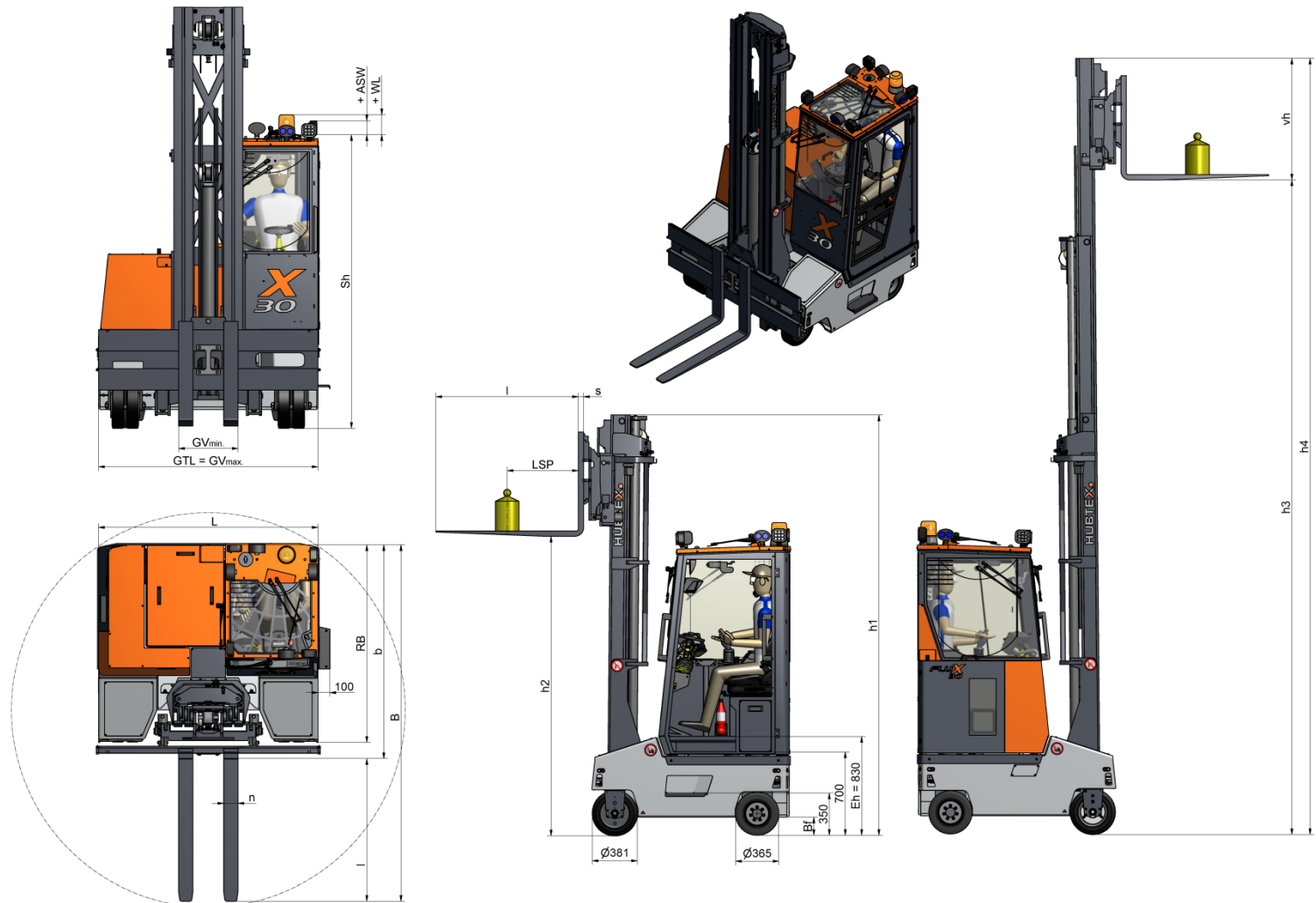

**ELECTRIC MULTIDIRECTIONAL COUNTERBALANCE FORKLIFT**

Characteristics	1.1	Series			2410-EL
	1.2	Model	Manufacturer's identification		FluX 30
	1.3	Capacity	Q at standard lift height	kg	3000
	1.4	Loadcenter	lc = distance	mm	600
	1.6	Power supply	electric / Diesel / LPG		electric
	1.7	Type of steering	V = fourway / M = multidirectional / 2 = towway		M
	1.71	Position of seat	Q = cross / D = diagonal / L = lateral / SU = stand up		Q
	1.8	Tyres	PU = Vulkollan / EL = elastic		EL
	1.9	Wheels (X = powered)	number	pcs.	6 / 2X
Dimensions	2.1	Mast	h3 = lift height standard / max.	mm	4000 - 7500
	2.21	Fork cross section	s / b = thickness / width	mm	45 / 120
	2.22	Fork length	l = from / to	mm	1200
	2.23	Fork tilt	Standard	degree	+5 / -5
	2.31	Overall dimensions	L = truck length	mm	1850 (+100 mm entrance step)
	2.32		Sh = height over cabin roof "Q"	mm	2465
	2.33		b = width to edge of forks	mm	1800
	2.34		NB = loadbed width from / to	mm	-
	2.35		B = truck width (at fork length 1200 mm)	mm	3000
	2.36		Rh = loadbed height	mm	-
	2.37		Eh = entrance height	mm	830
	2.38		Ra = loadbed opening	mm	-
	2.4	Mast reach	V (at fork length 1200 mm)	mm	-
2.52	Aisle width	AST (at fork length 1200 mm)	mm	2850 / 4000	
Wght.	3.1	Empty weight	incl. battery	appr. kg	7300
	3.2	Floor load	incl. nominal load (static)	N/cm²	220
Performance	4.1	Stability	according to CE-regulations	yes/no	Yes
	4.21	Speeds	travel speed with / without nominal load	km/h	10 / 10
	4.22		lifting speed with / without nominal load	m/s	0,22 / 0,30
	4.23		lowering speed with / without nominal load	m/s	0,35 / 0,30
	4.24		max. travel speed with / without nominal load	m/s	-
	4.31	Ramp capability	max. with / without nominal load	%	6 / 8
Wheels + tyres	5.11	Tyres	number load side / drive side	pcs.	4 / 2
	5.12		dimensions load wheels	mm	381 x 127
	5.13		dimensions drive wheels	mm	365 x 160
	5.3	Ground clearance		mm	150
	5.41	Service brakes			v. dr. p. act. electr. plugging br.
	5.42	Parking brake			spring-l. br. with electrom. rel.
Drive unit	6.11	Battery	capacity	V/Ah	48 V 5 EPzS 775 Ah
	6.12		minimum weight	kg	1130
	6.21	Electric motors	drive motor rating (s2 = 60 min)	kW	2 x 4,0
	6.22		lifting and steering motor rating	kW	1 x 8,0 / 1 x 3,0
	6.31	Electric controls	type		AC-controls
	6.4	Transmission	gear type		straight bevel
	6.5	Hydraulic pressure	for attachments	bar	180