

Series 2420 - EL, Model MaxX 30

HUBTEX.

- > Multidirectional steering
- > Electric drive
- > Capacity up to 3000 kg
- > Lift height up to 7500 mm
- > Loadbed width up to 1200 mm

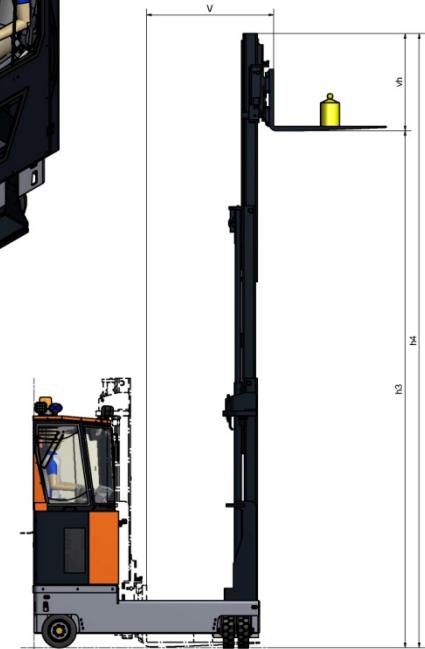
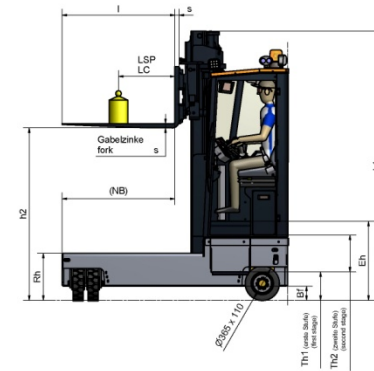
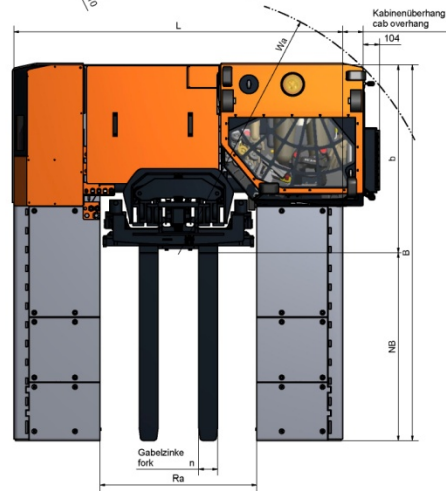
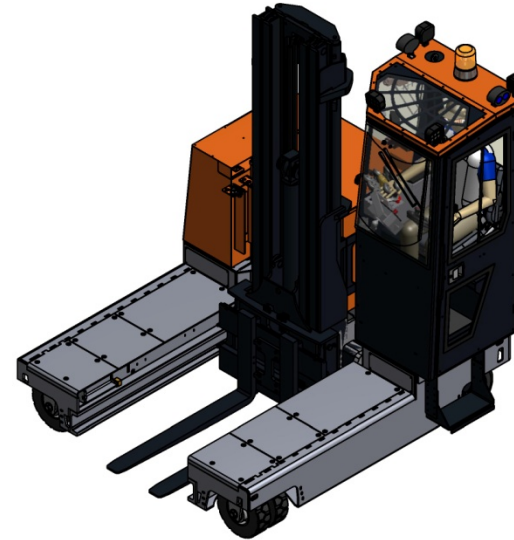

ELECTRIC MULTIDIRECTIONAL SIDELOADER

Characteristics	1.1	Series			2420-EL
	1.2	Model	Manufacturer's identification		MaxX 30
	1.3	Capacity	Q at standard lift height	kg	3000
	1.4	Loadcenter	lc = distance	mm	600
	1.6	Power supply	electric / Diesel / LPG		electric
	1.7	Type of steering	V = fourway / M = multidirectional / 2 = towway		M
	1.7.1	Position of seat	Q = cross / D = diagonal / L = lateral / SU = stand up		Q
	1.8	Tyres	PU = Vulkollan / EL = elastic		EL
	1.9	Wheels (X = powered)	number	pcs.	6 / 2X
Dimensions	2.1	Mast	h3 = lift height standard / max.	mm	4000 - 7500
	2.2.1	Fork cross section	s / b = thickness / width	mm	45 / 120
	2.2.2	Fork length	l = NB from / to	mm	800 - 1200
	2.2.3	Fork tilt	standard	degree	+5 / -3
	2.3.1	Overall dimensions	L = truck length	mm	2100
	2.3.2		Sh = height over cabin roof "Q"	mm	2510
	2.3.3		b = width to edge of forks	mm	1200
	2.3.4		NB = loadbed width from / to	mm	800 - 1200
	2.3.5		B = truck width (at NB 1200 mm)	mm	2400
	2.3.6		Rh = loadbed height	mm	500
	2.3.7		Eh = entrance height	mm	845
	2.3.8		Ra = loadbed opening	mm	1000
	2.4	Mast reach	V (at NB 1200 mm)	mm	1300
2.5.2	Aisle width	AST (at NB 1200 mm)	mm	2600 - 3400	
Wght.	3.1	Empty weight	incl. battery	appr. kg	5000
	3.2	Floor load	incl. nominal load (static)	N/cm²	300
Performance	4.1	Stability	according to CE-regulations	yes/no	yes
	4.2.1	Speeds	travel speed with / without nominal load	km/h	11 / 11
	4.2.2		lifting speed with / without nominal load	m/s	0,23 / 0,30
	4.2.3		lowering speed with / without nominal load	m/s	0,33 / 0,30
	4.2.4		mast travel speed with / without nominal load	m/s	0,20 / 0,20
4.3.1	Ramp capability	max. with / without nominal load	%	6 / 9	
Wheels + tyres	5.1.1	Tyres	number load side / drive side	pcs.	4 / 2
	5.1.2		dimensions load wheels	mm	377 x 127
	5.1.3		dimensions drive wheels	mm	365 x 160
	5.3	Ground clearance		mm	150
	5.4.1	Service brakes			v. dr. pedal act. electr. plugging br.
5.4.2	Parking brake			spring-l. brake with electrom. rel.	
Drive unit	6.1.1	Battery	capacity	V/Ah	48V5EPzS775Ah/48V6EPzS930Ah
	6.1.2		minimum weight	kg	1275
	6.2.1	Electric motors	drive motor rating (s2 = 60 min)	kW	2 x 4,0
	6.2.2		lifting motor rating	kW	1 x 8,0
	6.2.3		steering motor rating	kW	1 x 3,0
	6.3.1	Electric controls	type		AC controls
	6.4	Transmission	gear type		straight bevel
	6.5	Hydraulic pressure	for attachments	bar	180