

# Series 3051 - EL, Model DQ 70 / 80 - D/G

**HUBTEX.**

- Fourway steering
- Diesel or LPG powered
- Capacities up to 8000 kg
- Lift heights up to 6500 mm
- Loadbed width up to 1600 mm

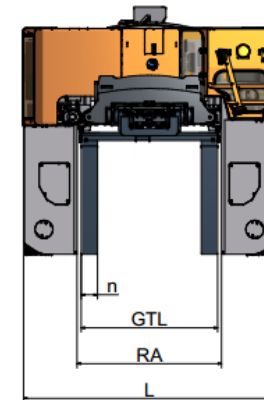
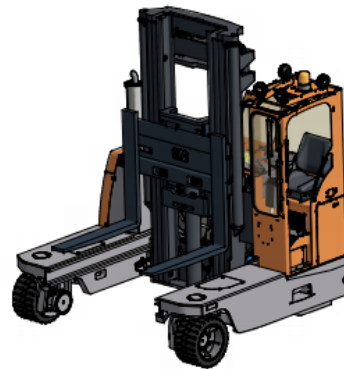
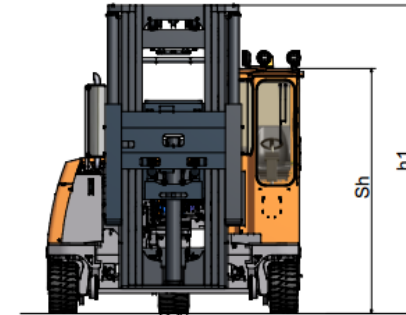
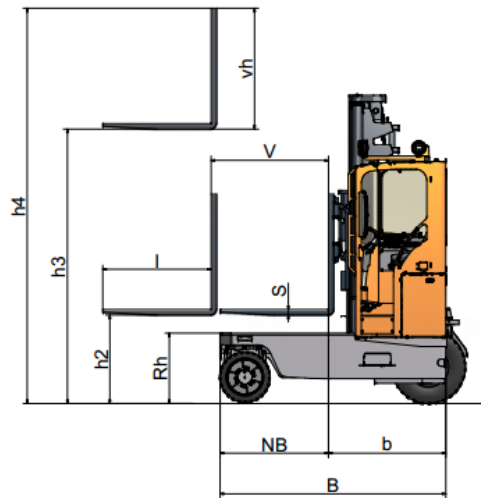

**DIESEL/LPG POWERED FOURWAY SIDELOADER**

Characteristics	1.1	Series		3051-EL				
	1.2	Model	Manufacturer's identification	DQ 70-D	DQ 70-G	DQ 80-D	DQ 80-G	
	1.3	Capacity	Q at standard lift height	kg	7000	7000	8000	8000
	1.4	Loadcentre	lc = distance	mm	600/700/800	600/700/800	600/700/800	600/700/800
	1.6	Power supply	electric / diesel / LPG		Diesel	LPG	Diesel	LPG
	1.7	Type of steering	V = fourway / M = multidirectional / 2 = twoway		V	V	V	V
	1.71	Position of seat	Q = cross / D = diagonal / L = lateral / SU = stand up		Q	Q	Q	Q
	1.8	Tyres	PU = Vulkollan / EL = elastic		EL	EL	EL	EL
	1.9	Wheels (X = powered)	number	pcs.	3 / 3X	3 / 3X	3 / 3X	3 / 3X
Dimensions	2.1	Mast	h3 = lift height standard / max.	mm	4000 - 6500	4000 - 6500	4000 - 6500	4000 - 6500
	2.21	Fork cross section	s / b = thickness / width	mm	60 / 180	60 / 180	60 / 200	60 / 200
	2.22	Fork length	l = NB from / to	mm	1200/1400/1600	1200/1400/1600	1200/1400/1600	1200/1400/1600
	2.23	Fork carriage tilt	standard	degree	+5 / -3	+5 / -3	+5 / -3	+5 / -3
	2.31	Overall dimensions	L = truck length	mm	2800	2800	2800	2800
	2.32		Sh = height over cabin roof "Q"	mm	2650	2650	2650	2650
	2.33		b = width to edge of forks	mm	1300	1300	1300	1300
	2.34		NB = loadbed width from / to	mm	1200/1400/1600	1200/1400/1600	1200/1400/1600	1200/1400/1600
	2.35		B = truck width (at NB 1200 mm)	mm	2500	2500	2500	2500
	2.36		Rh = loadbed height	mm	755	755	755	755
	2.37		Ra = loadbed opening	mm	1600	1600	1600	1600
	Wght.	2.4	Mast reach	V (at NB 1200 mm)	mm	1300	1300	1300
2.52		Aisle width	AST (at NB 1200 mm)	mm	2700 - 3500	2700 - 3500	2700 - 3500	2700 - 3500
Performance	3.1	Empty weight		appr. kg	12000	12000	12500	12500
	3.2	Floor load	incl. nominal load (static)	N/cm <sup>2</sup>	245	245	255	255
	4.1	Stability	according to CE-regulations	yes/no	yes	yes	yes	yes
	4.21	Speeds	travel speed with / without nominal load	km/h	12 / 13	12 / 13	12 / 13	12 / 13
	4.22		lifting speed with / without nominal load	m/s	0,30 / 0,32	0,30 / 0,32	0,30 / 0,32	0,30 / 0,32
Wheels + tyres	4.23		lowering with / without nominal load	m/s	0,35 / 0,30	0,35 / 0,30	0,35 / 0,30	0,35 / 0,30
	4.24		mast travel speed with / without nominal load	m/s	0,20 / 0,20	0,20 / 0,20	0,20 / 0,20	0,20 / 0,20
	4.31	Ramp capability	max. with / without nominal load	%	13 / 13	13 / 13	13 / 13	13 / 13
	5.11	Tyres	Anzahl load side / drive side	pcs.	2 / 1	2 / 1	2 / 1	2 / 1
	5.12		dimensions load wheels	mm	22x12-15 (559 x 305)		22x12-16 (559 x 305)	
	5.13		dimensions centre wheel	mm	400/60-15 (817 x 332)		400/60-15 (817 x 332)	
	5.3	Ground clearance		mm	200	200	200	200
	5.41	Service brakes			hydrostatic		hydrostatic	
Drive unit	5.42	Parking brake			hydromechanical		hydromechanical	
	6.11	Drive motor	brand		Kohler	GM	Kohler	GM
	6.12		capacity	kW	55	75	55	75
	6.21		speed	rpm	2600	2500	2600	2500
	6.22		cubic capacity	ccm	2500	4300	2500	4300
	6.23							
	6.31	Transmission	gear type		hydrostatic		hydrostatic	
	6.4							
	6.5	Hydraulic pressure	for attachments	bar	180	180	180	180