

HEAVY-DUTY TRANSPORT VEHICLES

**INDIVIDUAL
TRANSPORT
SOLUTIONS**



LOAD CAPACITIES OF UP TO 350 TONS

www.hubtex.com

HUBTEX.

WE CREATE THE UNIQUE

INDIVIDUAL, POWERFUL AND HEAVY-DUTY

Transporting heavy loads poses a significant challenge – one that we, as a specialist supplier with extensive experience are more than happy to face head-on.

In the face of ever increasing load weights and the rapid advancement of automation, development is in constant flux – making it all the more important for both customers and manufacturers to keep up to date at all times. The integrative HUBTEX modular system offers a variety of solutions, from manual to fully automated.

The HUBTEX Heavy-Duty series are typically used for in-house transport of heavy-duty goods in the automotive and aviation industries. It is also a popular solution at various stages of the value chain in the metal industry, from foundries to trade and processing in mechanical engineering.

Heavy-duty transport vehicles at a glance

Innovative ideas and powerful solutions are in demand, yet they must always remain cost-effective. We consider cost-effectiveness to be inextricably linked with quality and service. A solution tailored precisely to your application offers you maximum value, high availability and a long service life.

BRING YOUR IDEAS TO LIFE

When you come to us with your idea, HUBTEX will devise a concept which we will subsequently coordinate and refine with your input across multiple stages. At all times, you will benefit from the unrivalled expertise gained during our 35 years in the field of special machine manufacture.

TRUCK OVERVIEW

- Platform transporters p. 4
- Rail-mounted trucks p. 13
- Die handlers p. 14
- Electric traction head p. 16
- Automated guided vehicle systems p. 17

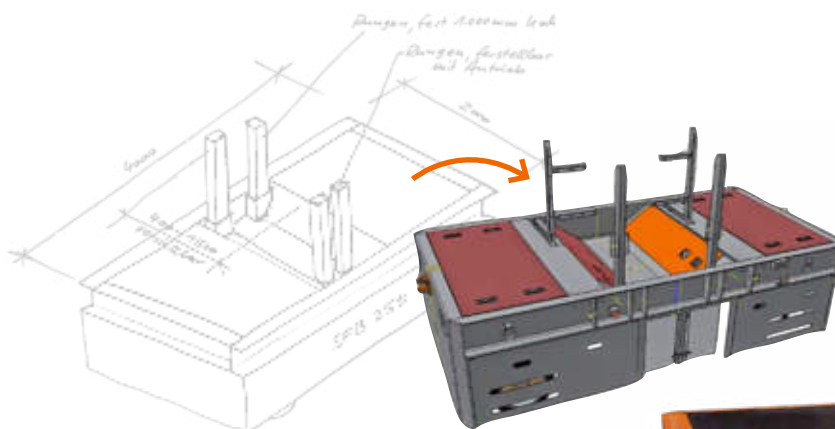

We develop tailored solution
concepts for our customers



PLATFORM TRANSPORTERS

SF-X – platform transporters



➤ Operation via remote control or from the cabin

➤ 2-way or multi-way steering for optimal manoeuvrability

➤ PU or PU Soft tyres for driving on asphalt, paving or industrial surfaces

➤ Indoor and outdoor operation combined or outdoor operation only

➤ Replacement of batteries from the side using a hand pallet truck or lift truck

➤ Load capacities of up to 65.0 t

➤ Robust construction

➤ Lift: choose from cylinder or lift platform

The new platform transporters from the SF-X series are available in the load classes 25 t, 40 t and 65 t.

The compact, self-propelled vehicles for indoor and outdoor use have a large loading area for the transport of heavy loads.

Thanks to its modular design, the inexpensive base of the transporter can be equipped with various steering systems and platform lift options or upgraded to an AGV.

Type	SF-X
Load capacity (t)	25 / 40 / 65
Steering	2-way or multi-way
Length (m)	4–6
Width (m)	2–3
Height (mm)	From 910
Drive	Electric via wheel hub
Tyres	PU and PU Soft
Battery	Lead-acid or Li-ion battery
AGV	Semi-automated to fully automated
Options	Comprehensive option package



➤ HIGH DEGREE OF FLEXIBILITY THANKS TO MODULAR SYSTEM

The high degree of modularity of the new platform transporters means that the vehicles can be adapted to a wide range of uses. The frame of the new SF-X is divided into three defined areas – the front axle, rear axle and centre section.

By modifying the interfaces of the assemblies, the length and width of the vehicle can be adjusted on an order-specific basis to suit the transport task. Thanks to pre-fabricated modules such as the wheel stool or the load wheel rocker and drive wheel rocker, comprehensive vehicle standards can be maintained.

BASIC EQUIPMENT

- *Solid sheet steel frame*
- *Underride protection*
- *Loading area in smooth sheet metal*
- *Power box*
- *HIT terminal*
- *Radio remote control*
- *LED safety lights*
- *Emergency stop button (2× per side)*
- *PU tyres*
- *Standard HUBTEX finishing*
- *Battery replacement from the side*

CUSTOMISATION OPTIONS

- *Frame extension*
- *Frame widening*
- *PU Soft tyres*
- *Finishing*

Two steering systems to choose from

Two different steering systems are available for our platform trucks. 2-way steering is the standard option in many areas of application. Multi-way steering is often recommended for smaller aisle widths.

Radio remote control

The new radio remote control option includes joysticks for more sensitive manoeuvring, emergency stop buttons, horn and upgradable options.

Power box

A hydraulic-electric cabinet can be used for all SF-X series. Depending on the requirements, the modular electrical panels can also be flexibly expanded to include AGV functions.

Running gear

The vehicles are designed with 2 axles as standard, but can be equipped with three or four axles to reduce the load on the ground.

Tyres

In addition to the standard, low-wear PU tyres for use on industrial surfaces, HUBTEX offers a PU Soft variant for variable surface conditions.

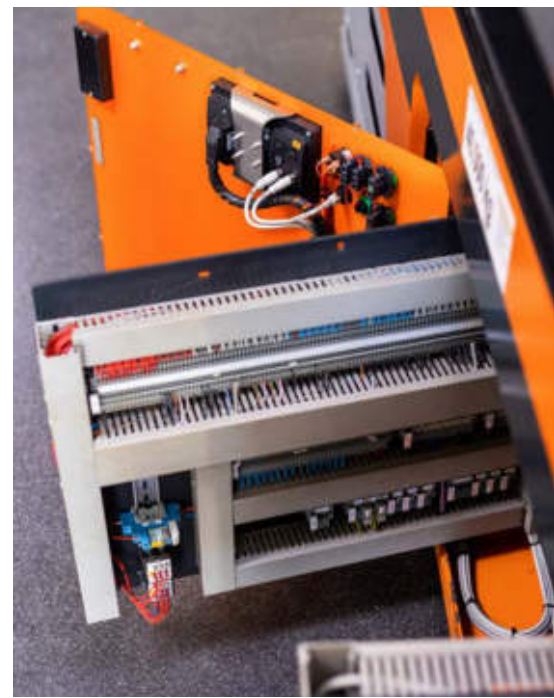
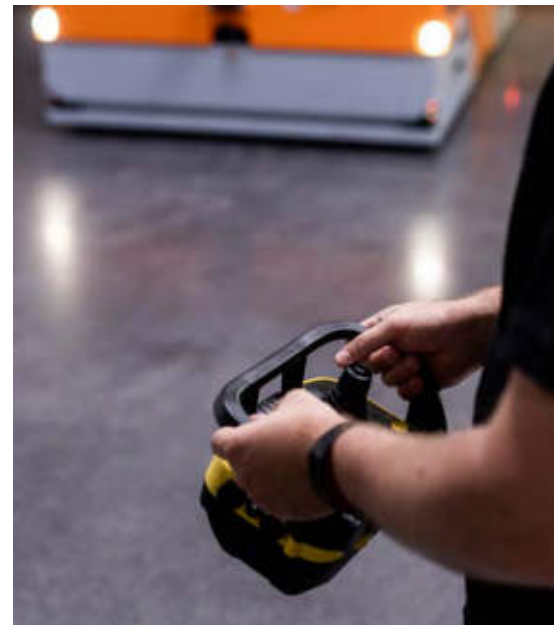



➤ EQUIPMENT VARIANTS AND OPTIONS

Lighting equipment

HUBTEX offers intelligent lighting options integrated into the running gear for optimal safety on your premises.

Emergency stop function

The emergency stop switch can be used to stop all driving and lifting functions immediately.

Tow coupling

Trailers or other accessory equipment can be attached to the vehicle with the tow coupling.

Blue arrow

The spotlight projects a blue arrow in front of the device in the direction of travel, thereby warning pedestrians of approaching vehicles.



The optional lift function controls either the cylinder or the entire platform.

➤ DRIVER'S CABIN / PLATFORM

These vehicles can be controlled from a seated or standing cabin as well as a cable remote control or radio remote control.

Thanks to the wide variety of modules, the vehicle can be adapted to many specific functions.



- Height-adjustable steering wheel
- 10"-LCD display in cabin for reversing camera
- Air-sprung driver's seat
- Ergonomic entry into cabin
- Two electrically adjustable exterior mirrors
- Four-sided glazing (laminated glass)
- Wiper and windscreen washer system



➤ BATTERY VARIANTS

- 80 V lead-acid battery with charging times between 5.5 and 12 hours
- 80 V lithium-ion battery with charging times between 1 and 2 hours

SAFETY

- Emergency stop buttons on all sides
- Underride protection on the front
- Distance sensors/assistance systems
- Optional personal protection equipment using laser scanner





➤ TWICE THE TOTAL LOAD CAPACITY IN COUPLING MODE

With particularly large loads, two or more vehicles can be used in coupling mode. A single load is thus distributed across multiple transporters. For example, the transporters drive under an aircraft fuselage where they are wirelessly coupled and remain in constant communication throughout the transport task. This creates a stable transport system with twice the total load capacity.



Transporting tools is a typical application for our SFBs.

Special variants

➤ MOVABLE PLATFORM

A movable platform enables transport of very long items such as load racks and moulded side parts.



➤ LOW PLATFORM HEIGHTS

Special versions of our platform transporters offer a load capacity of 35 tons with a construction height of only 457 mm. For transport purposes, the operator simply places the platform in front of the relevant load. The load is then semi-automatically positioned with

millimetre accuracy with the help of an assistance system. The vehicle determines its position by means of sensors before calculating the ideal steering geometry on this basis. The load is then raised using the integrated lift function.



The design principle of this transporter is the swing axle. It is guided by a rocker to which the load is transferred from a lift cylinder. This ensures optimal adaptation to uneven ground and variable heights.



GW – rail-mounted truck

The rail-mounted trucks (GW) from HUBTEX are configured to suit the individual needs and requests of our customers. Tried-and-tested components are used in the drives and control technology. The rail-mounted truck is designed to satisfy internal transport requirements.



- Robust construction
- Load-specific mounting options

- Individual frame production depending on specific application
- Battery or mains operation
- Maintenance-free AC drive technology
- Durable crane wheels

Type	GW
Load capacity (t)	Up to 350.0
Drive (V)	24 / 80 / 230 / 400 (electric AC)
Tyres	Rail wheel
Operation	Cabin / remote control / platform



Die handlers

Safe and as agile as possible – these are the key properties that modern die handlers must possess.

The HUBTEX die handlers with load capacities of up to 65 tons help to reduce changeover times of pressing and stamping tools, thereby increasing production efficiency. The compact running gear allows the vehicle to get as low as possible under the dies.



- Load capacities of up to 65.0 t
- Die table with lift heights of up to 3000 mm
- Extremely low table heights
yet high load capacities
- Die changes performed via a drive chain system
for rapid tool replacement



Easily adapted to different tool dimensions



Extremely low table heights

The vehicles have a large steering angle

When creating the concept for a HUBTEX die handler, we generally start with the requirement for a mobile and flexible solution with high positioning accuracy and implementation of a safe docking process for different machines as well as safe and rapid die changes.

- *Positive-lock plate
individually adaptable*
- *Multi-way steering*
- *Pedestrian-propelled
via remote control*
- *Hydraulic clamping device
for securing the dies during transport*



Example configuration

EFCSH – electric traction head with hydraulic gooseneck

The main applications of the HUBTEX seated electric towing tractor with hydraulic gooseneck are material provision in production areas, transport of heavy, compact machine components and handling of cargo trailers – e.g. frequent, safe and reliable transport of coils in outdoor storage yards, for instance.



- *Driver's seat position perpendicular to travel direction*
- *Ergonomic arrangement of the controls*
- *Maintenance-free AC drive motor*
- *Battery-powered electric drive*
- *Indoor and outdoor operation*

- *Three-wheel chassis with solid rubber tyres in a compact design*
- *System loads from 32 to 50 t*
- *Hydraulic gooseneck*

Type	EFCSH
System loads (t)	Up to 50.0
Battery (V)	80
Tyres	EL/PU

Automated guided vehicle systems

HUBTEX heavy-duty transport vehicles are ideally suited to automation. The use of an automated guided vehicle system reduces throughput times, saves costs and increases safety.

- *Increase in efficiency*
- *Optimisation of warehouse logistics*
- *Automatic load transfer*
- *Circular routes with stations*
- *Ideal for hazardous areas*



The advance of automated technologies

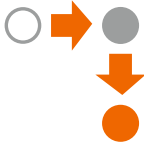

The increased complexity and dynamism of the areas of application mean that flexibility and scalability in logistics – and thus the automation of internal logistics processes – are steadily growing in importance. Although many companies have not yet made great progress in this field, they are now increasingly aware of the opportunities that the automation of warehouse and transport processes could

bring. Small and medium-sized companies, in particular, are increasingly considering whether an investment would be worthwhile. However, the calculation is complex and, as a result, the automation solution is rarely implemented. This is where it helps to seek advice from a specialist. HUBTEX calculates the costs for procurement, maintenance and adaptation and advises on how appropriate solutions

can be planned, designed and customised. One thing is clear: An automated solution usually requires a higher investment than a manual solution and the final costs are dependent on the degree of automation. However, given the potential saving in operating costs from running an automated system, this initial investment can be recouped very quickly.



MANUAL WITH A DRIVER



SEMI-AUTOMATIC



DRIVERLESS TRANSPORT VEHICLE (DTV)



AUTOMATED GUIDED VEHICLE SYSTEM (AGV)

When it comes to automation in logistics, there is no absolute standard. Companies can be completely manual or fully automatic. As a rule, the different logistics processes are automated to different degrees – ranging from driver-operated vehicles to semi-automatic vehicles and automated vehicles to fully automated systems. If AGV solutions are already in use, the company generally chooses over time to further increase the level of automation. It is therefore important that the technologies are flexible enough that the operator can independently administrate, set up and adapt the equipment to changes.



HUBTEX remote maintenance

➤ THE REMOTE MAINTENANCE SYSTEM AT A GLANCE:

- *Automatic exchange of information between truck and Service department*
- *Data transfer of error codes, battery charge status and operating hours*
- *Includes functions for changing parameters and initiating software updates*
- *Maximum machine availability, minimised production downtimes and service calls*

A remote maintenance system is available for HUBTEX vehicles. Important truck data, such as error codes and battery charge levels, is transferred to the cloud environment of our system partner Telekom via an M2M gateway on the lift trucks.

If the vehicle malfunctions, HUBTEX technicians can access the vehicle data directly and provide rapid assistance.



Customers benefit from maximum machine availability and minimised production downtimes. The system can also be retrofitted to used vehicles.



Rental or financing

➤ FINANCING SOLUTIONS

HUBTEX boasts one of the largest side loader fleets on the market. With 50 machines available for short- and long-term rental, we can provide the perfect solution for your individual application.

We are also happy to offer suitable financing for your new HUBTEX product. Our range of services encompasses everything from single vehicle leases to full-service packages, which also include replacement parts, maintenance and repair work.

HUBTEX VEHICLES

ELECTRIC-MULTIDIRECTIONAL-SIDELOADERS › DIESEL-/GAS-FOUR-WAY-SIDELOADERS › MULTIDIRECTIONAL COUNTERBALANCE FORKLIFT › ORDER PICKING SYSTEMS › GLASSTRANSPORT SYSTEMS › HEAVY DUTY TRANSPORT VEHICLES › REACH TRUCKS › SPECIAL TRUCKS › SECOND-HAND-AND RENTAL EQUIPMENT

HUBTEX.

WE CREATE THE UNIQUE

HUBTEX MASCHINENBAU GMBH & CO. KG · Industriepark West · Werner-von-Siemens-Str. 8 · 36041 Fulda, Germany
Tel.: +49 661 8382-0 · Fax: +49 661 8382-120 · info@hubtex.com · www.hubtex.com